

Dimensions

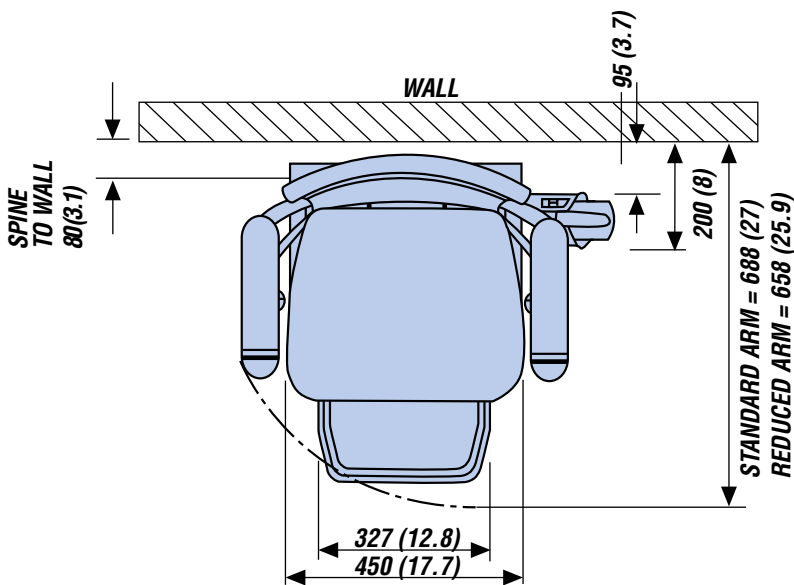

Dimensions:

All dimensions measured from the wall are nominal. The addition of a wide stringer or similar obstruction, may affect the dimensions taken from this point. Measurements are in millimetres, (measurements in brackets are in inches).

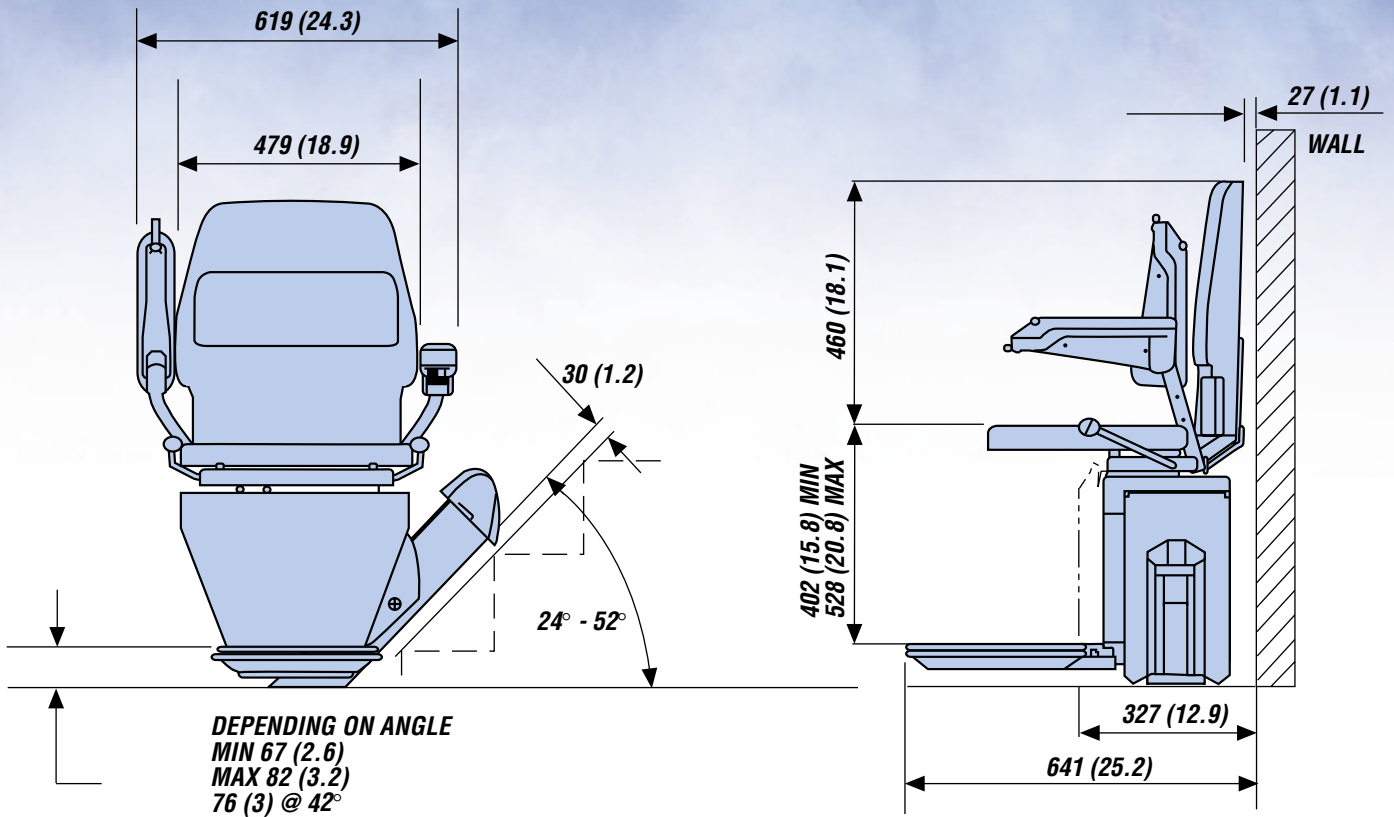

The world's most chosen stairlift

Rail

Construction	Extruded aluminium, box section rail.
Finish	Choice of aluminium or anodized finish.
Fixing	Brackets screwed to floor and staircase, no shrouds needed.
Min. Length of Rail	1.4m.
Max. Length of Rail	8m.
Rail Section Size	105mm wide x 112mm high.
Nominal Distance of Rail from Skirting	95mm.
Stair Nose to Rail	30mm.
Rail Overhang at Top	Short rail overhang available at all angles.
Rail Wiring	Inside rail.
Drive Method	Rack-and-pinion.
Max. Rail Incline	52°.

Seat

Seat Type	Armchair seat - swivels to face landing.
Materials	Steel frame, with flame retardant upholstered backrest and seat. Conforms to BS7176, resistance to ignition.
Armrests	Two sturdy hinged armrests with soft polyurethane upper surface. One housing directional controls, one housing on/off rocker switch.
Switches	Removable 'on/off' key under arm. Low pressure joystick for up/down. On/off rocker switch on arm. Battery isolator switch mounted on the carriage.
Load	Up to 45° 135kg (approx 21 stone). 45° – 52° 120kg (approx 19 stone).
Manual Swivel Control	Once the stairlift has reached the top landing, push down on the swivel lever to release the swivel mechanism which allows the seat to be turned manually.

Carriage

Construction	Steel fabrication.
Finish	Epoxy powder-coated
Motor	DC powered, Input 0.25 kw, Output 0.13 kw
Start	Cushioned start/stop.
Speed	0.1 m/sec ± 20%
Electronics	Electronic control unit.
Safety Features	Overspeed governor stops carriage at 0.3 m/s max. Safety pads operate safety switches located around carriage. Stairlift works in the event of power cuts.
Servicing	Annually.
Batteries (carriage)	2 x 12 volt 7Ah.

Footrest

Construction	Cast aluminium alloy.
Finish	Epoxy powder-coated to match carriage.
Carpet	Pile with latex back, conforms to BS4790.
Safety	Safety pads operate safety switches in direction of travel.

Other fittings

Landing Call Switches	Surface-mounted controls at top and bottom of stairs have soft-touch up/down switches.
Charge Unit	Wall or floor mounted, 24V two stage unit.



Design, manufacture and installation:
Stannah model 300 and components have been tested and approved to BS 5776 1996, CSA, TUV, DLI, Machinery Safety Directive 98/37/EC, Low Voltage Directive 73/23/EEC and EMC Directive 89/336/EEC.

Our company policy is one of continuing product improvement. We therefore reserve the right to alter the specifications and to change and improve the design at any time. Full operating instructions are supplied for all products.

Stannah Stairlifts Jan 2001
STAIR/300/030

www.stannah.com

Stannah Stairlifts Limited, Watt Close, Andover, Hampshire, SP10 3SD, England
Tel: +44 (0) 1264 364311 Fax: +44 (0) 1264 362276 e-mail: marketing@stannah.co.uk

Dealer stamp



The world's most chosen stairlift